

# Electric platform truck 1.5 ton

## **Simai**

*Four wheel-series*

PE15.1



# Electric platform truck 1.5 ton

Truck specifications					PE15.1
Identification	1.1	Manufacturer			Simai S.p.A
	1.2	Model			PE15.1
	1.3	Drive			Electric
	1.4	Operator type			Sit-on
	1.5	Load capacity/rated load	Q	kg	1500
	1.5.1	Towing capacity	Q	kg	10000
	1.7	Rated drawbar pull	F	N	2200
	1.9	Wheelbase	y	mm	1900
Weight	2.1	Service weight		kg	1645
	2.2	Axle load, with load, front/rear		kg	1085 / 2220
	2.3	Axle load, without load, front/rear		kg	925 / 720
Wheels	3.1	Tyre - Cushion(Cu), Extra-elastic(SE), Pneumatic(Pn),Polyurethane			SE/Pn
	3.2	Wheel size, front			4.00-8
	3.3	Wheel size, rear			18x7-8
	3.5	Wheels, number front/rear (x = driven wheels)			2/2x
	3.6	Track width, front	$b_{10}$	mm	845
	3.7	Track width, rear	$b_{11}$	mm	924
	Dimensions	4.7	Height of cab	$h_6$	mm
4.8		Seat height	$h_7$	mm	990
4.8.1		Step on platform height		mm	480
4.12		Coupling height	$h_{10}$	mm	410 - 355 - 300
4.13		Loading height	$h_{11}$	mm	550
4.16		Length of loading surface	$l_3$	mm	1700
4.17		Overhang	$l_5$	mm	880
4.18		Width of loading surface	$b_9$	mm	1100
4.19		Overall length	$l_1$	mm	3095
4.21		Overall width	$b_1$	mm	1160
4.32		Ground clearance, centre of wheelbase	$m_2$	mm	120
4.35		Turning radius front	$W_a$	mm	3000
4.35.1		Turning radius rear		mm	2330
4.36		Internal turning radius	$b_{13}$	mm	1580
4.36.1		Aisle width when turning 90°		mm	2180
Performance data	5.1	Travel speed, with/without load		km/h	15 / 18
	5.6	Max. drawbar pull		N	8000
	5.7	Gradeability		%	See chart
	5.8	Max. gradeability loaded/unloaded		%	See chart
	5.10	Service / parking brake (I=Hydraulic E=Electromagnetic M=Mechanical)			I / E
	5.10.1	Type of service brake front/rear			Drum / wet brakes
Electric motor	6.1	Drive motor rating S2 60 min		kW	2 X 6,6
	6.3	Battery according to DIN 43531 / 35 / 36 A, B, C, no			43531 A
	6.4	Battery voltage, nominal capacity <sup>1)</sup>	$K_5$	V/Ah	48/ 420 - 460 - 500
	6.5	Battery weight		kg	667 - 700 - 731
	6.6	Energy consumption according to EN 16796		kWh/h	1,43
Others	8.1	Electronics control			Inverter AC
	8.4	Sound level at driver's ear according to EN 12053		dB(A)	69

<sup>1)</sup> Performances and weight are intended with 500 Ah battery.

As per VDI guidelines 2198, this datasheet applies to standard electric tractor / platform truck only. Dimensions are not binding and can be changed in any moment. The performances must be intended for brand new machines, after having completed the running-in tested in San Donato Milanese factory in normal climatic conditions. Performances and weight are to be intended with standard motors and battery and with pneumatic tires. Some data can vary according to different equipments.

## Dimensional Drawing

### EXAMPLE OF GRAPH READING:

TOWED LOAD =  $1,5t + [2t]$

GRADIENT (i) = 5 %

DRAWBALL PUL (F) = 3900 N

SPEED (V0) = 10 km/h

MAX. PRACTIBLE RAMP LENGTH (s) = 9 km

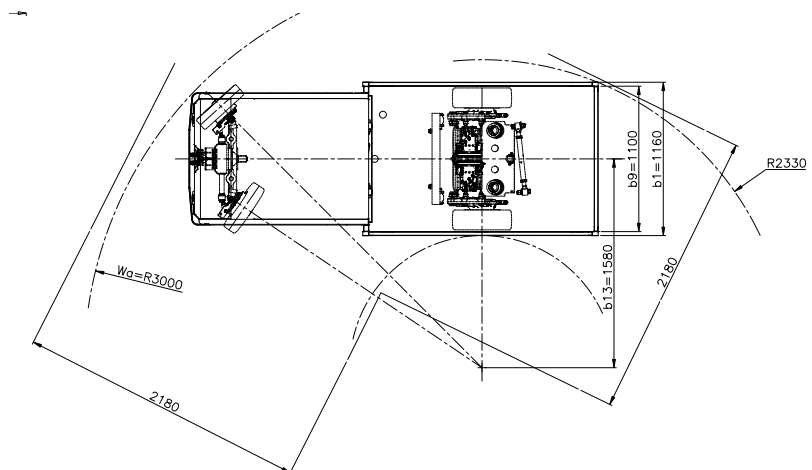
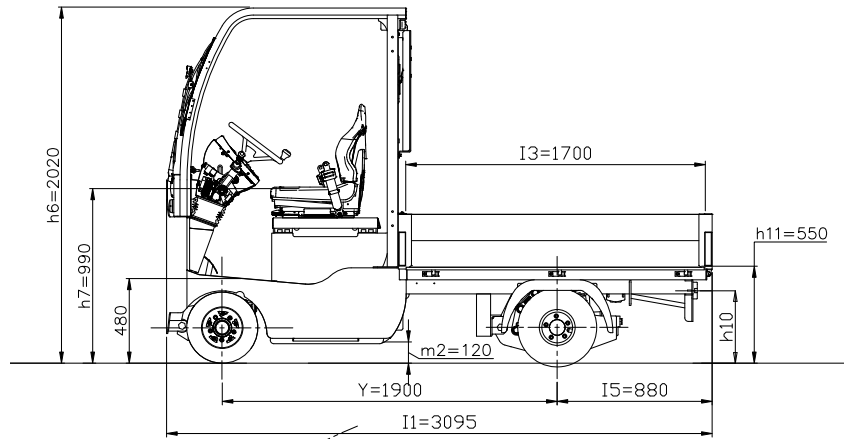
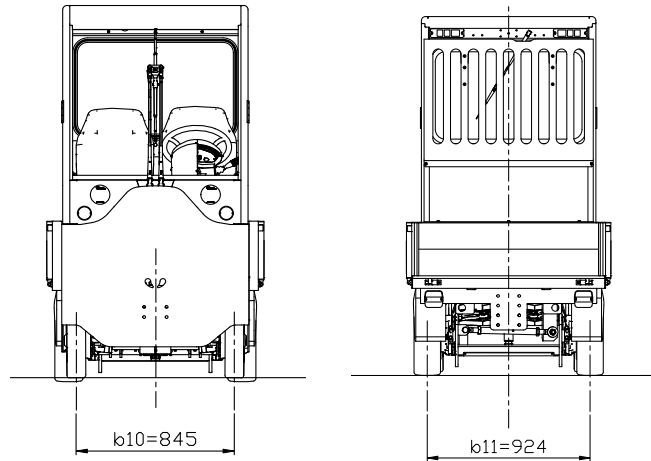
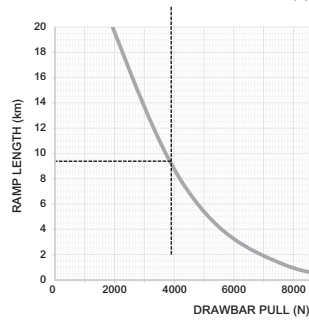
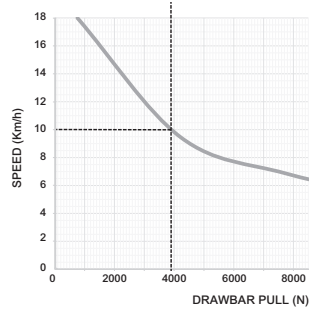
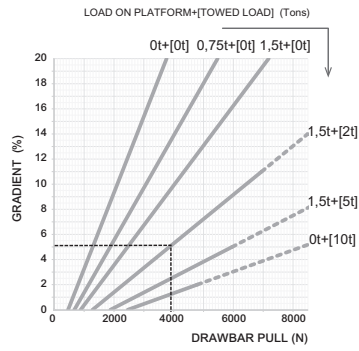

## Standard equipments:

- AC power system
- Hydraulic steering
- Pneumatic tyres
- Automatic parking brake
- Regenerative braking
- Head and tail lights, turn signal lights
- Digital display

### **GABELSTAPLER CENTER KAMEN**



02307 - 208150



info@gabelstapler-center.de



www.gabelstapler-center.de

Gabelstapler-Center Kamen  
GmbH & Co. KG  
An der Seseke 30  
59174 Kamen